

PRODUCT DATA SHEET

Part number	610509
EAN	4015609023264
Manufacturer	WALTER-WERKE
WEEE-Reg.-Number:	DE 22131895

Product description

Wall appliance inlet for external fixing 16A 5P 9h with one top cable entry



Similar image



Detailed product description

WALTER Wall appliance inlet 16A 5P 230V 9h IP44
 made from PA6 material
 for external fixing
 and with one top cable entry

Ordering Information

Order unit	Piece
Customs number	85366990
Net weight	0,177 kg
Packing quantity (VPE)	10
Length of the packaging	
Width of the packaging	
Depth of the packaging	
Gross weight(VPE)	1,77 kg

Certificates

VDE certification	123018	
EAC certification	BY112.02.01.020 06091	

Classification system

Classification system	ETIM_6.0
ETIM Class	EC001319

Technical product data

IEC-amperage	16 A
Amperage acc. UL/CSA (for UL-version)	20 A
Number of poles	5
Voltage acc. EN 60309-2	230 V (50+60 Hz) blue
Clock hour position	9 h
Identification colour	Blue
RAL-number	5002
Degree of protection (IP)	IP44
Connection system	Screwed terminal
Connection type	Wall mounted plug
Angle of plug	Angled
Material	Plastic

Dimension sheet

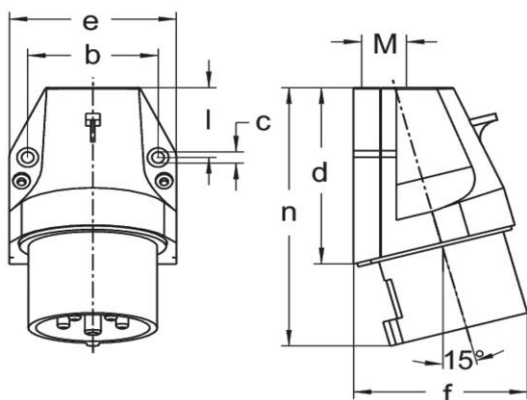

Amp.	16			32		
	3	4	5	3	4	5
b	45,5	60	60	60	60	60
c	5,3	5,3	5,3	5,3	5,3	5,3
d	74	80	80	97	97	97
e	60	74	74	82	82	82
f	60	73	73	80	80	86
l	28	31	31	45	45	45
n	110	117	117	141	141	141
M	20	20	20	25	25	25